

About the product

The Loxone Wallbox is a charging station which enables dynamic charging from 1.38kW to 11kW for electric vehicles. With the robust Tree interface, the device is integrated into the Loxone system and provides all the freedom for energy management. To record the electrical energy, an energy meter can be easily mounted on the integrated DIN-rail and connected to the Modbus interface in the device. Optionally, products like the NFC Code Touch, Touch Pure Flex,... can be mounted directly on the device to set your charging mode or execute any other control.

Ambient conditions

Ambient temperature	-20...50°C / -4...122°F
Ambient humidity	max. 95% r.H. (non condensing)
Degree of Protection	IP44 (IEC 60529) IK08 (IEC 62262)
Installation	Stationary, surface mount, vertical on wall or charging post
Recommended mounting height	Cable outlet: 132cm / 52" Top edge: 165cm / 65"
Altitude	max. 2000m

Electrical Data

Supply and Power	AC Input (mains)	24V DC Input
Rated voltage	3x 230/400V or 1x 230V, 50-60Hz	18-24V
Current	3x 16A or 1x 16A	max. 400mA
Power consumption	-	Standby: 0.3W, charging: 3W

Charging

Max. charging power	11kW (3 phase 16A) / 3.7kW (1 phase 16A) configurable from 1.38kW to 3.7/11kW
Charging Mode	Mode 3 (IEC 61851-1)
Residual current detection	Internal, RDC-MD, DC 6mA, (IEC 62955)
Charging cable with plug	Type 2 plug (IEC 62196) 5 meter cable, 5x2.5mm ² + 1x0.5mm ²

Interfaces

Loxone Tree	connection with Miniserver / Tree Extension
Modbus RTU for connecting Energy meters	max. 1 device, max. 0,5m wire length, adjustable baud rate & parity, data types: 16 & 32 bit, min. polling cycle: 5s

Installation must be carried out by a qualified electrician in accordance with the relevant regulations.



For more information
about this product, visit
loxone.com/help/wallbox-tree

**Loxone
Electronics GmbH**
Smart Home 1
4154 Kollerschlag
Austria

Loxone UK
The Forum
Station Road
Theale, RG7 4RA
United Kingdom



For additional information,
declaration of conformity, visit
www.loxone.com/datasheets

V120523

Need Help?
loxone.com/support



Wallbox 11kW 16A Tree

Part No.: 100526

LOXONE

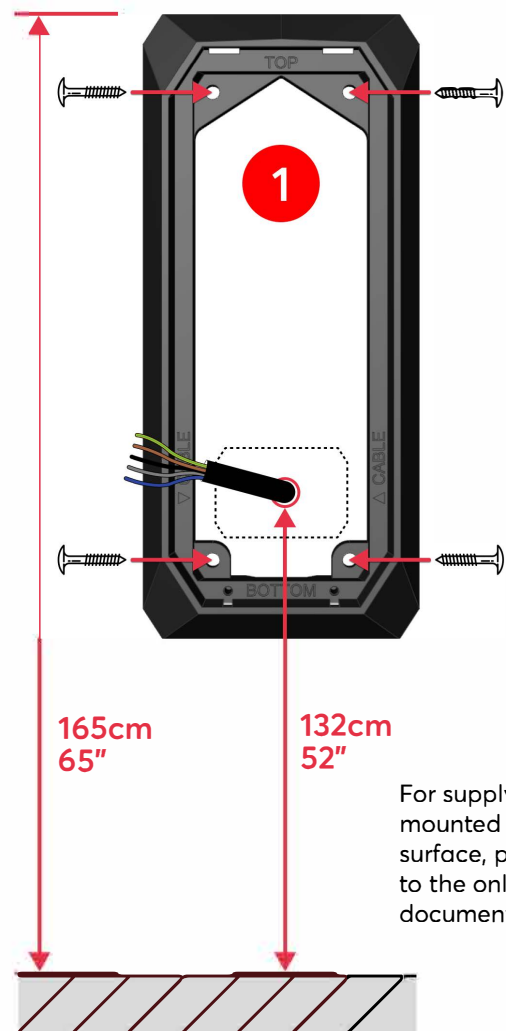

For supply cables mounted on the surface, please refer to the online documentation.

Torque: max. 2Nm / 1.48lb-ft

