

# 12,8 Volt Lithium-Iron-Phosphate Batteries Smart With Bluetooth

www.victronenergy.com

## Why lithium-iron-phosphate?

Lithium-iron-phosphate (LiFePO<sub>4</sub> or LFP) is the safest of the mainstream li-ion battery types. The nominal voltage of a LFP cell is 3,2V (lead-acid: 2V/cell). A 12,8V LFP battery therefore consists of 4 cells connected in series; and a 25,6V battery consists of 8 cells connected in series.

### Rugged

A lead-acid battery will fail prematurely due to sulfation:

- If it operates in deficit mode during long periods of time (i.e. if the battery is rarely, or never at all, fully charged).
- If it is left partially charged or worse, fully discharged (yacht or mobile home during wintertime).

A LFP battery does not need to be fully charged. Service life even slightly improves in case of partial charge instead of a full charge. This is a major advantage of LFP compared to lead-acid.

Other advantages are the wide operating temperature range, excellent cycling performance, low internal resistance and high efficiency (see below).

LFP is therefore the chemistry of choice for very demanding applications.

### Efficient

In several applications (especially off-grid solar and/or wind), energy efficiency can be of crucial importance. The round trip energy efficiency (discharge from 100% to 0% and back to 100% charged) of the average lead-acid battery is 80%.

The round trip energy efficiency of a LFP battery is 92%.

The charge process of lead-acid batteries becomes particularly inefficient when the 80% state of charge has been reached, resulting in efficiencies of 50% or even less in solar systems where several days of reserve energy is required (battery operating in 70% to 100% charged state).

In contrast, a LFP battery will still achieve 90% efficiency under shallow discharge conditions.

### Size and weight

Saves up to 70% in space  
Saves up to 70% in weight

### Expensive?

LFP batteries are expensive when compared to lead-acid. But in demanding applications, the high initial cost will be more than compensated by longer service life, superior reliability and excellent efficiency.

### Bluetooth

With Bluetooth cell voltages, temperature and alarm status can be monitored.  
Very useful to localize a (potential) problem, such as cell imbalance.



12,8V 300Ah LiFePO4 Battery

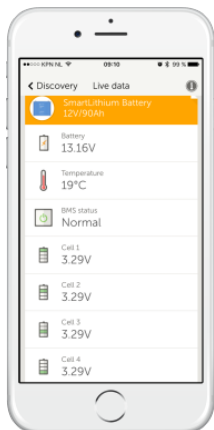

Li-ion app

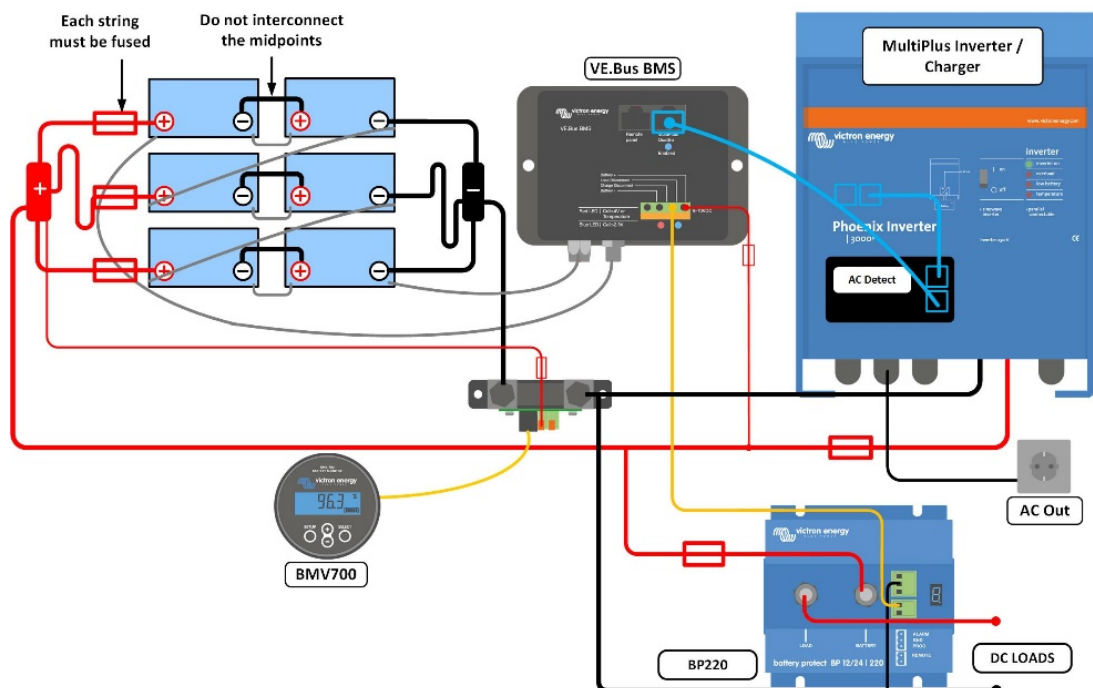

Our LFP batteries have integrated cell balancing and cell monitoring. Up to ten batteries can be paralleled and up to four batteries can be series connected, so that a 48V battery bank of up to 3000Ah can be assembled. The cell balancing/monitoring cables can be daisy-chained and must be connected to a Battery Management System (BMS).

### Battery Management System (BMS)

The BMS will:

1. Disconnect or shut down the load whenever the voltage of a battery cell decreases to less than 2,5V.
2. Stop the charging process whenever the voltage of a battery cell increases to more than 4,2V.
3. Shut down the system whenever the temperature of a cell exceeds 50°C.

See the BMS datasheets for more features

Battery specification					
VOLTAGE AND CAPACITY	LFP-Smart 12,8/60	LFP-Smart 12,8/90	LFP-Smart 12,8/160	LFP-Smart 12,8/200	LFP-Smart 12,8/300
Nominal voltage	12,8V	12,8V	12,8V	12,8V	12,8V
Nominal capacity @ 25°C*	60Ah	90Ah	160Ah	200Ah	300Ah
Nominal capacity @ 0°C*	48Ah	72Ah	130Ah	160Ah	240Ah
Nominal capacity @ -20°C*	30Ah	45Ah	80Ah	100Ah	150Ah
Nominal energy @ 25°C*	768Wh	1152Wh	2048Wh	2560Wh	3840Wh
*Discharge current ≤1C					
CYCLE LIFE (capacity ≥ 80% of nominal)					
80% DoD	2500 cycles				
70% DoD	3000 cycles				
50% DoD	5000 cycles				
DISCHARGE					
Maximum continuous discharge current	120A	180A	320A	400A	600A
Recommended continuous discharge current	≤60A	≤90A	≤160A	≤200A	≤300A
End of discharge voltage	11V	11V	11V	11V	11V
OPERATING CONDITIONS					
Operating temperature	-20°C to +50°C (maximum charge current when battery temperature < 0°C: 0,05C, i.e. 10A in case of a 200Ah battery)				
Storage temperature	-45°C to +70°C				
Humidity (non-condensing)	Max. 95%				
Protection class	IP 22				
CHARGE					
Charge voltage	Between 14V and 14,4V (14,2V recommended)				
Float voltage	13,5V				
Maximum charge current	180A	270A	400A	500A	750A
Recommended charge current	≤30A	≤45A	≤80A	≤100A	≤150A
OTHER					
Max storage time @ 25°C*	1 year				
BMS connection	Male + female cable with M8 circular connector, length 50cm				
Power connection (threaded inserts)	M8	M8	M10	M10	M10
Dimensions (h×w×d) mm	240×285×132	249×285×160	317×335×228	297×425×265	347×425×265
Weight	12kg	16kg	33kg	42kg	51kg
*When fully charged					